

Sez. A-A

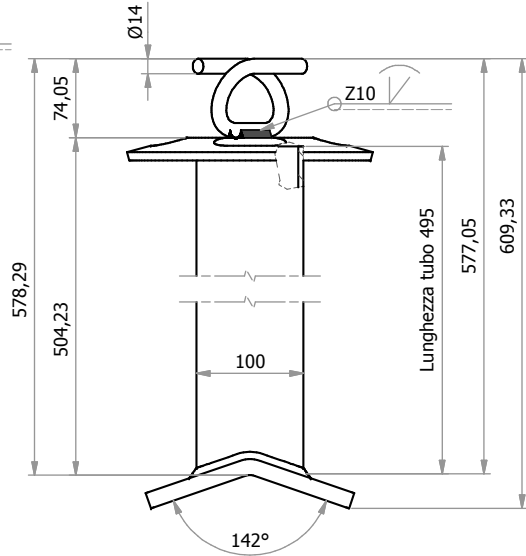

Rappresentazione della marcatura
Scala 1:3

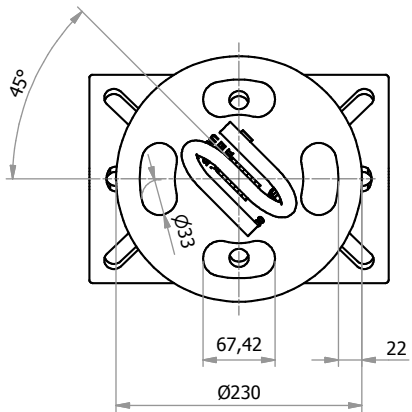
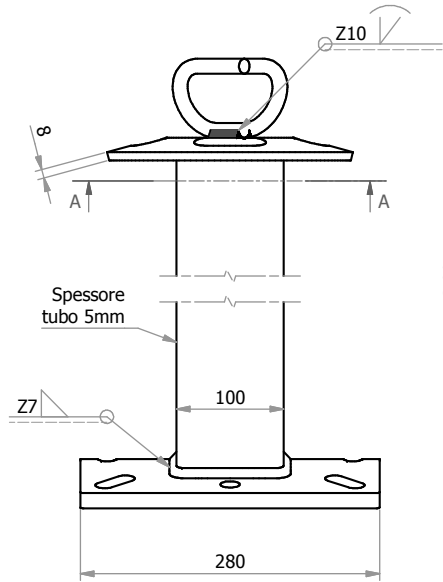
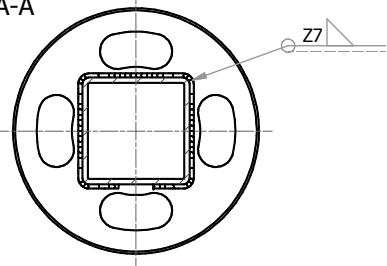
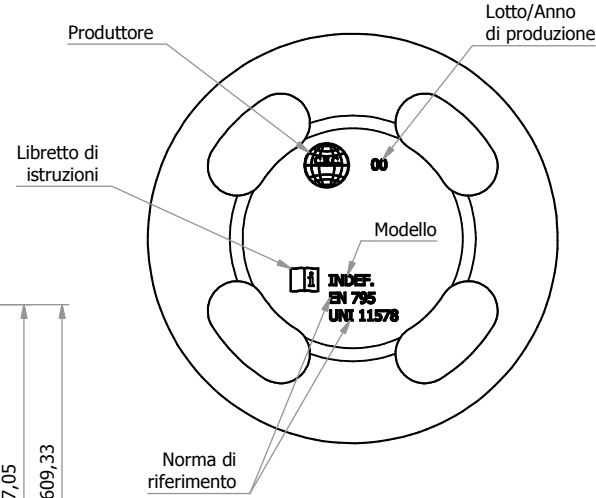

Rappresentazione base piana (cod. 902A.2)
con posizione fori ed asole (scala 1:5)

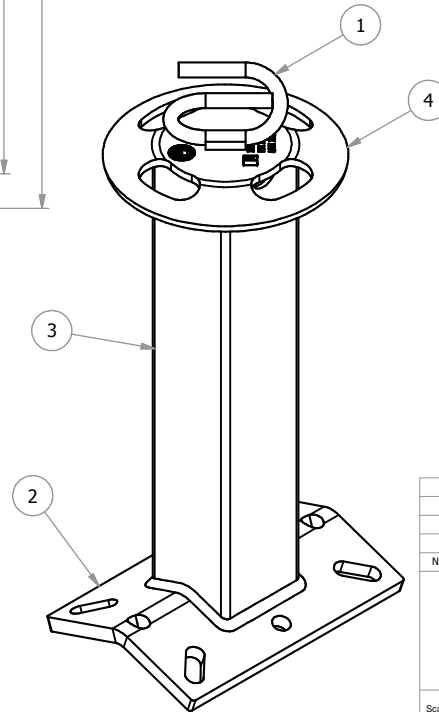
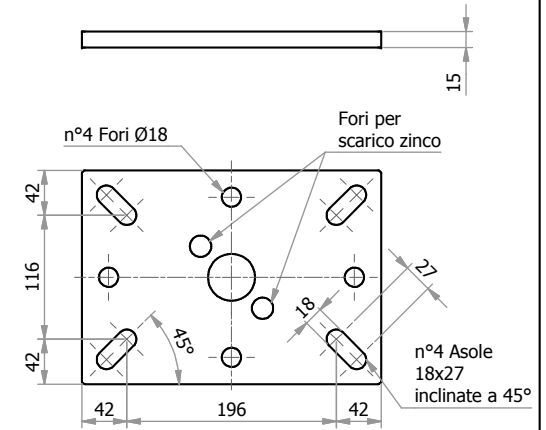
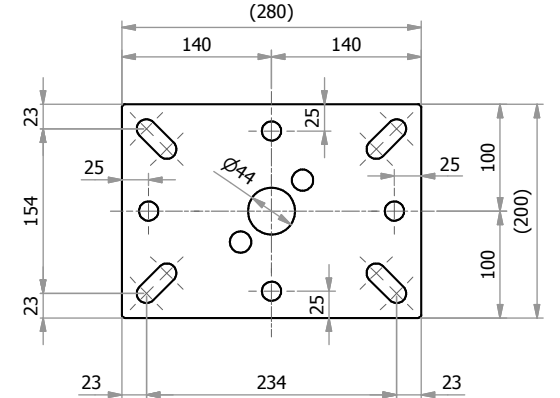

N°	CODICE	DESCRIZIONE	MATERIALE	Q.TÀ
4	901PS	Flangia per torretta	S 235 JR (Fe 360 B)	1
3	03TUB406	Tubo 100x100 SP=5 L=495	S 235 JR (Fe 360 B)	1
2	902A.2P	Base 200x280 Sp=15 piegata per torretta	S 235 JR (Fe 360 B)	1
1	904C	Gancio per torretta	S 235 JR (Fe 360 B)	1

N°	Data	Modifica	Eseguito da	
C.S.C. s.r.l. ATTREZZATURE PER LA SICUREZZA Via Europa, 1 - 42015 Correggio (Reggio Emilia) Italia Tel. +39 0522 732009 - Fax. +39 0522 732059 www.cscedilizia.com		Cliente: 	N° Commessa	N° Sezione
Descrizione: Torretta H=500 doppia falda 200x280		Sostituisce il: 	Sostituito da:	
Scala: 1:4		Note: Materiale: S 235 JR (Fe 360 B)		Peso kg. 15,7 kg
Disegnato da: H.D. Data: 01/07/14 Verificato da: E.B.		Trattamento: Zincatura a caldo		N° Pezzi: Codice: 406-50